



FRYERS

FRYERS

WHY?

Because our fryers are the results of an intense activity of research and development carried on together with our customers throughout the years. We can now present our forth generation, representing the technological vanguard of the market. This equipment guarantees **optimal performances, low energy consumption and excellent cooking results.**

The optional devices designed by Inoxpiù also ensure **dramatic savings on oil waste** and make **cleaning procedures an easy and quick task.**

THE CHARACTERISTICS:

Innovative Technology

Inoxpiù fryers are amazingly quick: only 4 or 5 minutes to reach the ideal frying temperature. Just like all the rest of Inoxpiù's production, the new fryer is equipped with electronic temperature control. The importance

of this device is dual: it allows to set temperature very precisely (variations can be made degree by degree) and also avoids oil to attain smoke point. The special structure of the frying vat favours convective movements, helping distribute heat evenly to oil and therefore improving frying quality.

Our fryers are also equipped with ***Energilogic***, an **electronic device that guarantees great amounts of energy savings** and that ensures an average consumption of only 2,5kW (calculated on a 10 Lt. fryers in laboratory tests).

The innovative structure and positioning of heating resistances offer a constant heat storage. This helps maintain **set temperature steady and allows to regain it quickly** even when frozen food is poured into the fryer: the result is crunchy, light and golden fries.

The exclusive and patented building system also protects the heating devices so that break-downs and maintenance become a minor and rare worry.

Easy use, easy cleaning

Inoxpiù has always paid close attention to equipment's design, not only for aesthetic purposes, but also to offer products that can be easily cleaned and sanitized.

The **digital displays** are extremely handy when it comes to cleaning: no holes, nubs or fissures, the



control panels do not jut out and can be cleaned in a few seconds.

The exclusive **all-round lip prevents dirt and detergents from falling into the frying vat** thus contaminating oil. Once the lid is in place, it clutches with the lip, the oil is hermetically isolated, shielded from light and external agents.

Genius: the smart vat

Another innovative and patented solution by Inoxpiù is **Genius**, a revolutionary technology.

During the frying process, the remnants of fried food tend to stick to the vat's walls, deteriorating oil quality and altering the taste of the products.

Genius is a special "glove-vat" designed to perfectly fit inside the frying vat, covering its inner walls. **By removing it, you will also get rid of most of the frying remnants** since they will have got caught onto *Genius'* walls.

The "glove-vat" can indeed be removed, washed in the dishwasher and fitted again in place in a matter of minutes.

This amazing device helps save time and money: it helps **maintaining oil cleaner** and also dramatically **reduces the downtimes** needed for vat cleaning.

Also available as an optional is a **special removable splash-board** that can be positioned along the three free sides of the fryer to help maintain cooking top and environment cleaner.

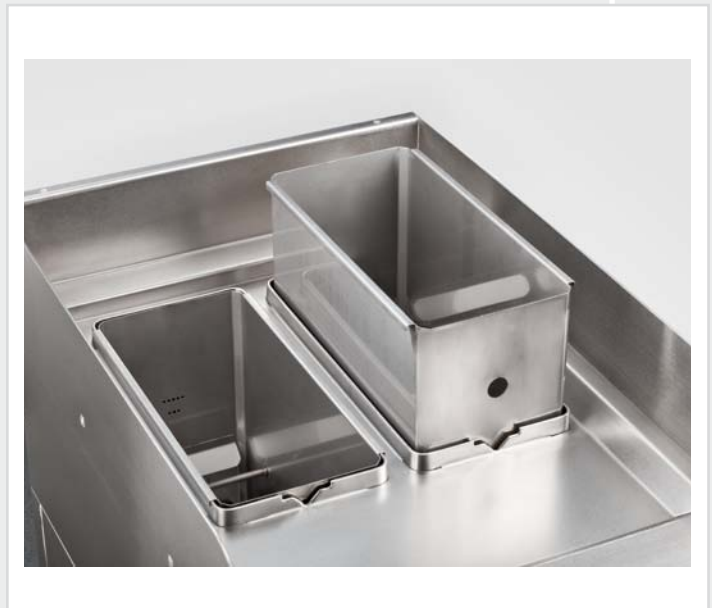

Flexibility at your service

All models can be equipped with feet or wheels and can be provided as a free-standing machine or can be inserted in our modular or monoblock cooking units.





ECO-FRY: the smart filtering system

Our fryers can be equipped with ECO-FRY, the revolutionary integrated oil filtering system with electronic management patented by Inoxpiù.

It is a compact device designed to filter and purify frying oil, lowering and maintaining “polar compounds” concentration below tolerance level (by law fixed at 25%).

THE ADVANTAGES:



Savings on oil cost up to 90% . Passing through a special filter for free polar compounds, oil is constantly regenerated.



Besides great savings on the cost of oil, *Energilogic* system guarantees **very low energy consumption**.



Using constantly regenerated oil means a consistent and high quality of cooking. The result will be **lighter, healthier and crunchier food**.



Filtered oil also helps **eliminating odours and smells**, keeping the kitchen cleaner and fresher.

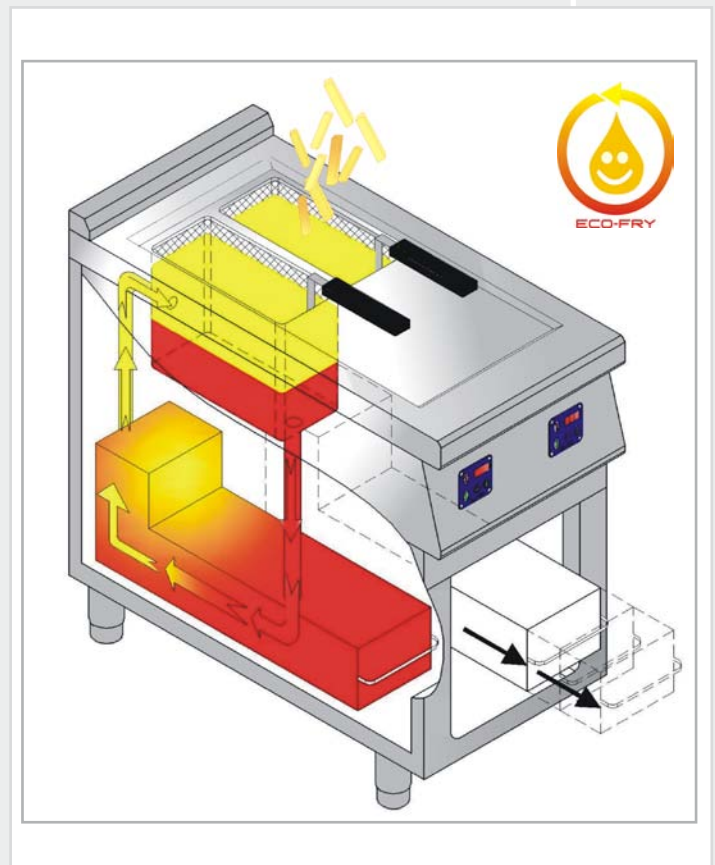

Besides adding every now and then a small percentage of oil naturally absorbed by food, you will **not need to change the whole load of oil anymore**. The oil stays clean.

The **filtering takes place automatically**, there is no need of any technical knowledge whatsoever. Push a button and the integrated system will start the process automatically.

Washing the filter is also extremely easy: a cycle in the dishwasher it is all it takes to eliminate residue.

Thanks to a **special “storage-box”** oil can be stored safely while you clean the frying vat with detergents, ensuring maximum hygiene and preserving oil from contamination.

Eco-fry has been designed as an “on-board” optional, compact and practical without any external bulky device to help you save space.

Eco-fry is a precious tool that allows you to **eliminate energy and oil wastes and increase productivity and food quality**.





TECHNICAL CHARACTERISTICS

Model	10 litres	10+10 liters	20 liters
<i>External dimensions</i>	450 x 60/70/90mm 300 x 60/70/90mm	450 x 60/70/90mm	450 x 60/70/90mm
<i>Vat dimensions (exp. in mm)</i>	331x157x127h	331x157x127h x 2	329x340x109h
<i>Vat capacity (min/max)</i>	9/10	9+9/10+10	19/20
<i>Vat number</i>	1	2	1
<i>Power</i>	7,8 kW	7,8 kW	7,8 kW
<i>Input</i>	400V/3/N/PE	400V/3/N/PE	400V/3/N/PE

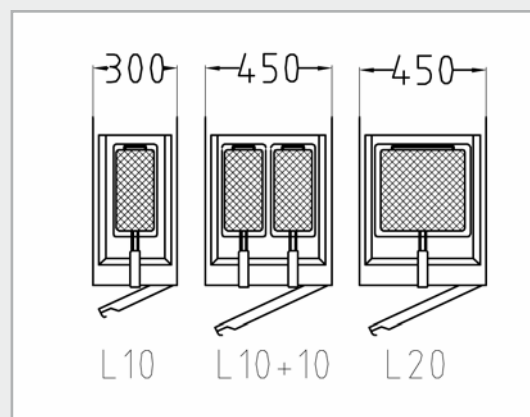



Inoxpiù Srl

**via Provina 18, Loc. Ravina
Trento (TN) - Italia
tel. +39 0461 923149
fax +39 0461 911572
www.inoxpiu.com**